

CAMERA WORKS

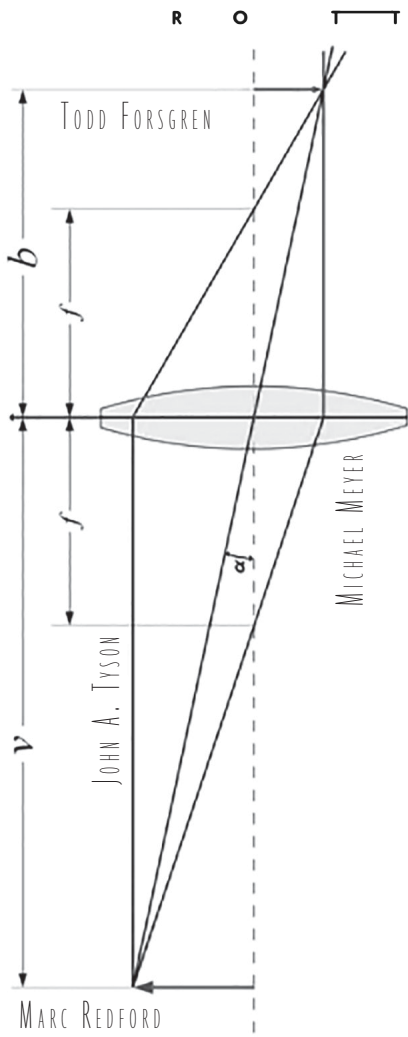



FRAMING PHOTOGRAPHY'S APPARATUS:

The Camera Works of Todd Forsgren, Michael Meyer, and Marc Redford

Photography has long been associated with veracity: it has the potential to capture realistic images, typically the result of a mechanical process and reflecting a specific set of actual light conditions. Despite its apparent truthfulness, we know photography is often entangled with duplicity too. Since the medium's inception, its tools have been endlessly improvised, iterated, and improved. But evolutions in photographic technology are Janus faced too. Advances move both in the direction of higher fidelity to reality as well as toward more artful artifice; we often think that developments in the former variety happen in cameras and lenses, while those of the latter stripe occur in the dark room or computer desktop. Alfred Stieglitz, an early champion of photography as an artistic medium, was committed to the idea of "truth" as "the basis of all works of art." However, as Otto Beck observes in an essay in the first issue of Stieglitz's deluxe art photography publication *Camera Work*, aesthetic integrity was not anathema to particular kinds of "faking": describing the shortcomings of "straight photographers," he asserts that they: "failed largely because they attempted to complete their picture outwardly before the camera." He continues, "Here... lies

the difference between art and artificiality.”

Todd Forsgren, Michael Meyer, and Marc Redford’s projects for RotterdamPhoto also artistically address truths: they zoom out and reframe Beck’s early-twentieth-century notion of photography, plumbing the gap between “art and artificiality.” These photographers do not merely employ cameras to produce pictures; instead, these tools are integral to their respective meta-photographic projects. By bringing cameras into the purview of art, their works poetically examine their role in delimitating photography as well as the devices’ own limitations. They prompt viewers to think about how cameras abstract the realities they record and transfix. Redford, Meyer, and Forsgren’s artistic endeavors might best be understood as “camera works”—a punning moniker, which literally describes their artworks’ primary component as well as evoking a longer history medium specificity.

Todd Forsgren’s *Constant Surveillance* (ongoing) collapses the technology of nascent photography and our image-saturated present. With pinhole cameras he records spans of hours or even years, catching every moment and no single moment simultaneously. Although the project evokes panoptic disciplinary technology, its images are decidedly more aesthetic. Installed in Rotterdam, his work will create an expanding archive of contact prints throughout the

festival. Unlike the standard, time-stamped surveillance images, Forsgren's photos resist bearing the trace of a singular moment in regimented clock time. Nonetheless, their literal, indexical linking his analogue feed to its surrounds is important too. Recalling the tautological logic of Robert Morris's *Box with the Sound of Its Own Making* (1961) (a cubic wooden sculpture with a recording inside), the temporality of exhibition becomes coextensive with that of image production in Forsgren's poetic surveillance.

Michael Meyer reacts to the complexity of contemporary photographic tools of creation, dissemination, and consumption, black boxes that few fully understand. Drawing upon information freely available on the internet and as well relying on grassroots dissemination of technological knowledge via electronic communities, Meyer makes his own digital cameras. Thus, in building his *Single Pixel Cameras* (ongoing), he takes control of his means of production. In addition, he radically reigns in the photographic form in his machines' output. By isolating single pixels for his images, he implicitly raises questions about the relation between the slice of reality that is converted into the basic element of twenty-first-century images: How do size and colors change with the translation to the language of pixels? What is the threshold of invisibility in the digital age? Meyer creates photography degree zero: he

works at the point where presentation becomes representation; any further reduction would mean the end of the image (or perhaps merely the birth of immanence).

Marc Redford combs flea markets and charity shops for loaded cameras. He processes and prints their hidden treasures: photographs abandoned by strangers. In *Latent* (ongoing) Redford acts as a curator of anonymous snapshots, selecting long-forgotten scene from each camera to juxtapose the machines that caught them. Both the apparatus and images become objects of visual—and sociological—interest. Unearthed and unmoored in time and presented in a new context, the intimate snapshots open a strange window into the lives of their previous owners. Gazing upon far away scenes of family and holiday destinations viewers search for indexes they might use, detective-like, to produce narratives about content portrayed. Spectators, moreover, confront the history of image-making also; the camera mass of shiny black plastic hangs heavily from straps on the wall, prompting us to remember the preciousness these tools acquired in many families. Presented in an art context in 2018, the latent images and technology take on uncanny qualities, seeming almost to hail from a past that is, as L.P. Hartley writes in *The Go-Between*, “a foreign country” where “they do things differently.”

Redford, Meyer, and Forsgren position the camera squarely within the frame of spectatorship, in some sense laying bare this optical technology. They call upon beholders to study their apparatuses with the same curiosity and care they would photographs. Hence, for engaged viewers, their camera works might catalyze new processes of understanding the device's truth, or even the commencement of therapeutic working through—a coming to terms with—the camera.

John A. Tyson
New York City
2018





Todd Forsgren
Constant Surveillance, 2017





Marc Redford
Installation with *Latent #11* & *Latent #47*, 2010

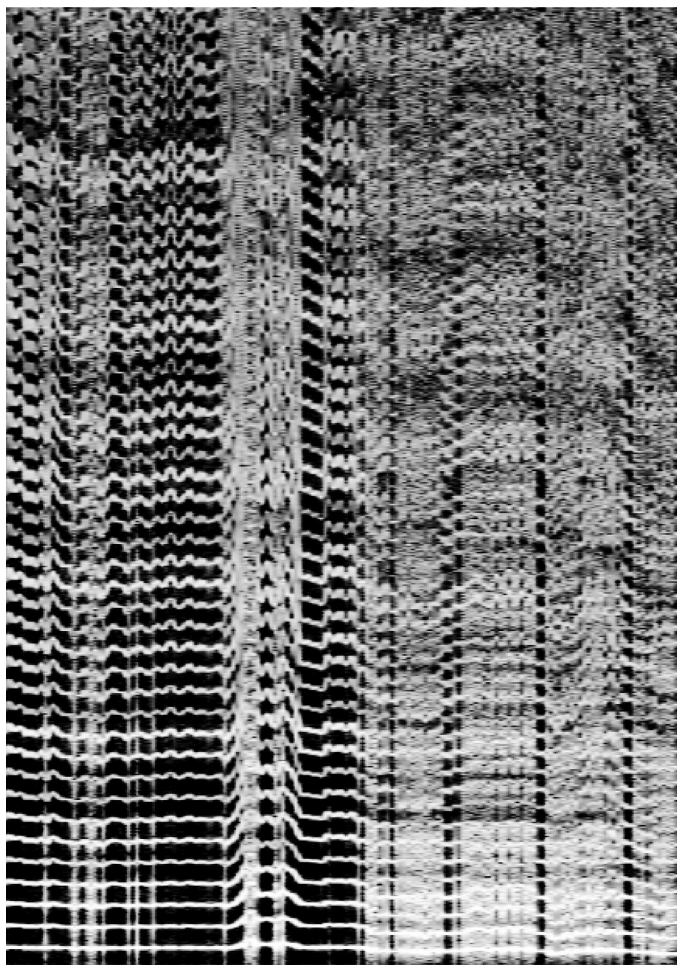



Michael Meyer

Sound Camera B9804, 2017 (above)

Single Pixel Picture B9804_20171107-021, 2017 (opposite)

Todd Forsgren

Todd Forsgren uses photography to explore themes of ecology, environmentalism, and perceptions of landscape, while striking a balance between art history and natural history. To do so, he employs a range of photographic approaches, from documentary strategies to experimental techniques. His series *The World is Round* twists and turns the medium in a playful ontological examination of photography.

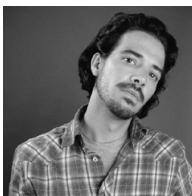

Michael Meyer

Through visual and audio recording tools Michael Meyer examines how lives interconnect, how ideas converge and bounce off of one another, and how the world is changing moment by moment. Immersing himself in the flow of time, he pulls out fragments for examination and remixes them into a semblance of his world.



Marc Redford

Whilst exploring themes relating to the stimuli that provoke us to create images, Marc Redford fluctuates between the role of curator and photographer in searching for images lost or yet to be realised. At times seeking and documenting forensic traces of another's presence, rooted in the craft of photography, he revels in the alchemy of the darkroom and imagine a latent photographic archaeology that is continually being discovered.



John A. Tyson (Curator)

John Tyson is an assistant professor at the University of Massachusetts, Boston. From 2015-2017, he was the Andrew W. Mellon Postdoctoral Curatorial Fellow at the National Gallery of Art. In his scholarship and curating he engages artworks that resist categorization or intervene in the institutions that frame them. Tyson view art as a form of knowledge production, which can prompt reflection on received truths.

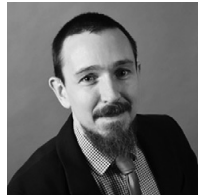

R O



R
D
A
M



2
|
O
-
O
社